



A registered trademark of Quantum Sphere Pty Ltd.

Brackets & Mounts for Flat Screens

Motorised Mounts

Projector Mounts

Projection Screens

Audio Visual Furniture

HDMI Cables and Accessories

Trade Show and Digital Signage

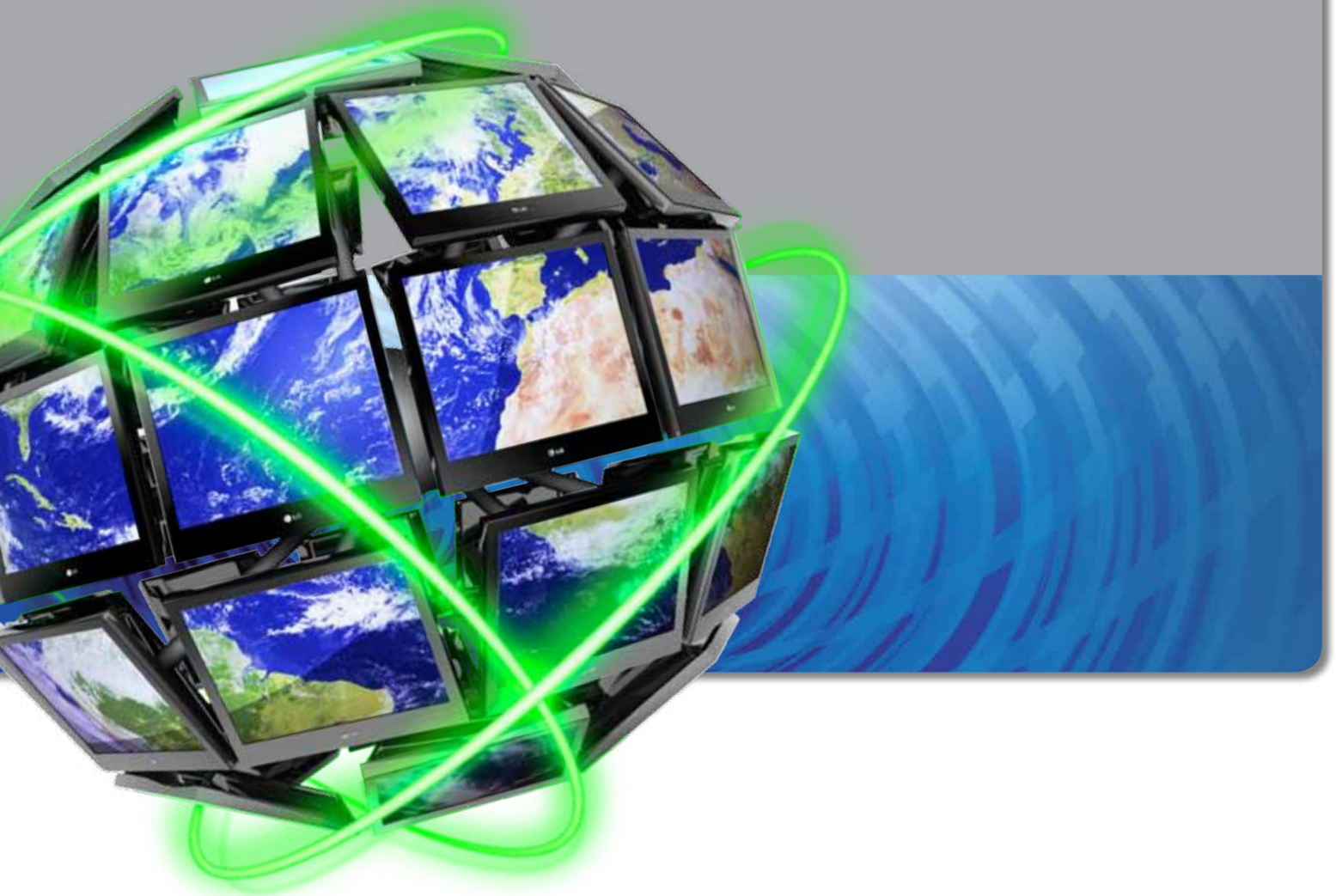

QUANTUM SPHERE





**Welcome to Australia's best range of brackets and mounts for AV applications.**

Q-Tee Brackets & Mounts are distributed throughout Australasia by Quantum Sphere. Q-Tee is part of an established export and manufacturing enterprise, its partners cover the world. We have established ownership with continuing investment in manufacturing facilities located in China. Q-Tee aims to be Australia's leading source for brackets, mounts, and accessories for display devices.

**Comprehensive product line.**

Q-Tee offers the most comprehensive range of brackets for Plasma & LCD screens, projectors, video & hi-fi and speakers. Whether mounting on the wall, the ceiling, table or the floor, Q-Tee has the solution to suit your budget for both domestic and commercial applications. Additionally to our extensive line up, we also supply a range of projection screens (tripod, manual pull down with auto lock and electric motorised screens). All made from 'matte white' fabric to suit today's modern projectors.



We have also introduced a range of Audio Visual furniture that features integrated mounting brackets. i.e. one box / one solution, featuring stylish black tempered glass and brushed aluminum finishes making it aesthetically pleasing for any commercial or residential application.

**Focus on quality**

Q-Tee mounts are engineered to the highest quality and made according to ISO9001 standards. You have spent thousands of dollars on your home entertainment system, the last thing you want is a flimsy, inferior mount supporting your display device.



**Exceeding Standards**

The majority of our mounts not only support VESA standards but support those screens with non-VESA mounting hole patterns. We even exceed this standard in most cases with integrated support for VESA 50 / 75 / 100 / 200.

**Choosing the right bracket and mounts.**

Q-Tee products are designed to fit VESA standards as well as Non-VESA standards to make installation quick and easy... The VESA (Video Electronic Standards Association) Standard defines mounting interfaces, hole patterns, and associated cable/power supply locations for plasma displays, LCD/LED monitors, and other flat panel TV devices. Q-Tee mounts attach to both of VESA's most common interfaces with ease. Sometimes, large screen displays will be Non-VESA standardised, Q-Tee solutions are also suitable for these. Finding a suitable mount for your requirements should be a straight forward process in most instances.

As an example of VESA 100, there should be 4 screw-holes in a square pattern, 4mm in diameter - usually located in the centre or towards the bottom of any monitor. Most small models, from most manufacturers, are now made to this standard.



**Contents**

Fixed TV Mounts	3,4
Tiltable TV Wall Mounts	5
Articulated TV Mounts	6,7
Motorised TV Mounts	8
Low Profile Mounts	9
Ceiling Mounts	11,12
Projector Mounts	10
Desktop / Table Mounts	12
Tradeshow & Digital Signage	13
AV Furniture	14,15,16
Cables & Accessories	16
Projection Screens	17,18
Quantum Sphere	19

**More help.**

A helpful legend key has also been included to assist you in your selection of products.

Choose the Right Bracket & Mount

-  Supported display sizes
-  Load rating
-  VESA Compatability

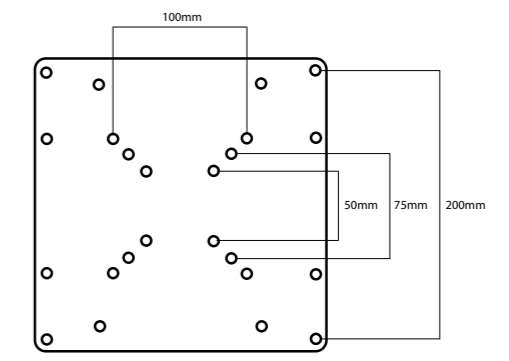

Fixed TV Mounts

LDC-201

- Flat, flush mount bracket
- Supports VESA 75/100
- Very low profile (13mm gap)
- Maximum loading capacity: 30kg
- Solid steel construction
- Silver / black colour

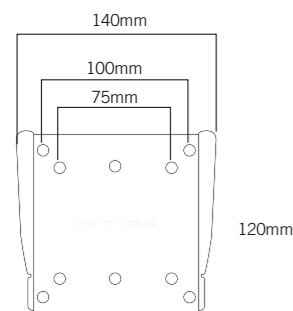
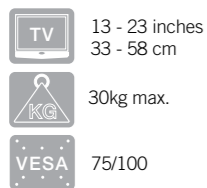

Fixed TV Mounts

LDC-201L

- Flat, flush mount bracket
- Supports VESA 50/75/100/200x100/200
- Very low profile (13mm gap)
- Maximum loading capacity: 35kg
- Solid steel construction
- Silver / black colour

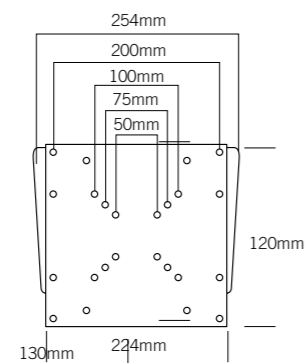
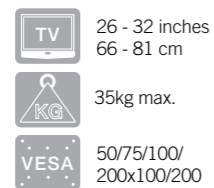

Fixed TV Mounts

TK-1 7in1 COMPLETE KIT

- Black Colour
- Low profile design, TV to wall: 30mm
- Universal fixed mounting pattern
- Max TV hole spacing: 830mm wide and 405mm high



Available in Black

- CABLES
- 3m 1080p gold plated HDMI cable, 30awg
  - 3m gold plated RF antenna cable, 9.5mm plug to 9.5mm jack

- CABLE SOCK
- 3m 40mm wide polyester cable sock

- CLEANING KIT
- 60ml non-drip cleaning liquid
  - Soft anti-static cleaning brush
  - 30x30cm Microfibre cloth

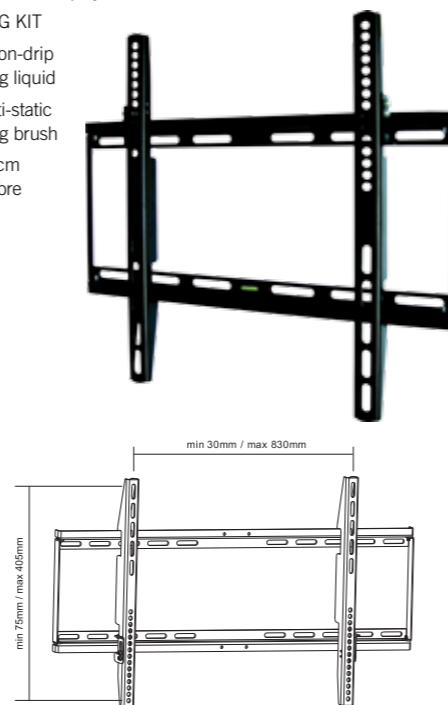

Fixed TV Mounts

PB-17

- Supports 23" - 37" Screens
- Maximum loading capacity: 75kg
- Available in silver or black
- 510mm wide x (75 to 330mm) high

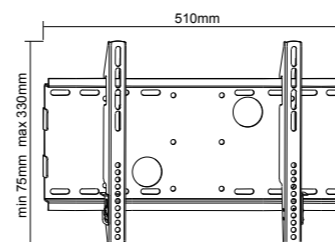
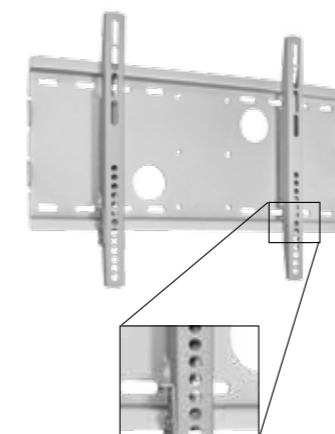

Fixed TV Mounts

PB-13

- Flat, flush mount bracket
- Supports 37" - 63" Screens
- Maximum loading capacity: 75kg
- Very low 30mm profile
- Available in silver or black
- 800mm wide x (75 to 480mm) high

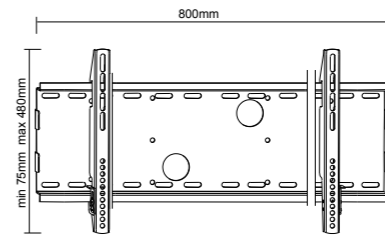
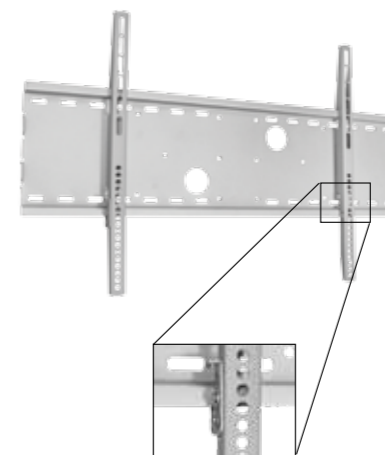

Fixed TV Mounts

PB-13 XXL WIDE

- Flat, flush mount bracket
- Supports 65" - 85" Screens
- Maximum loading capacity: 75kg
- Very Low 30mm Profile
- Available in black only
- 1110mm wide x (75 to 600mm) high

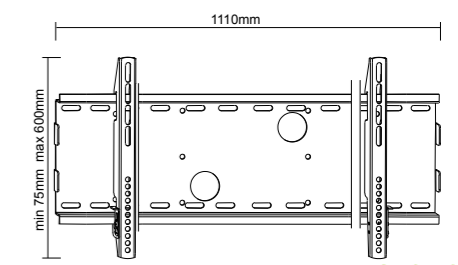
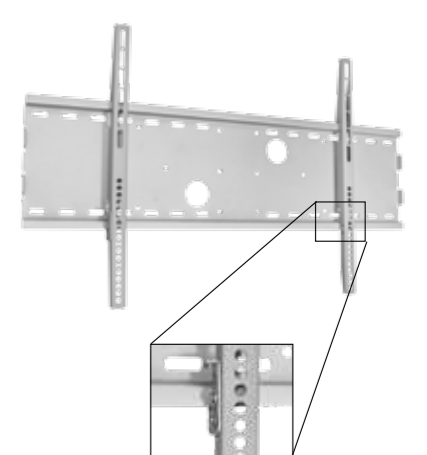
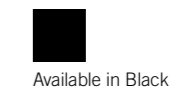
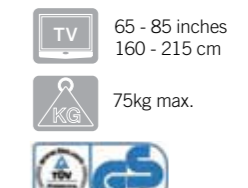

Tiltable TV Wall Mounts

**PB-18**

- Vertical tilt bracket  $\pm 15^\circ$
- Supports 23" - 32" Screens
- Maximum loading capacity: 75kg
- Available in silver or black
- 510mm wide x (75 to 330mm) high



Available in Silver or Black

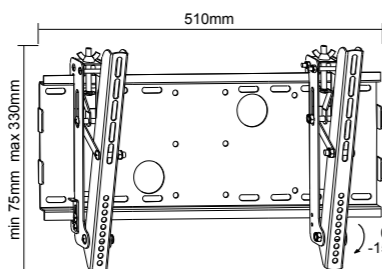
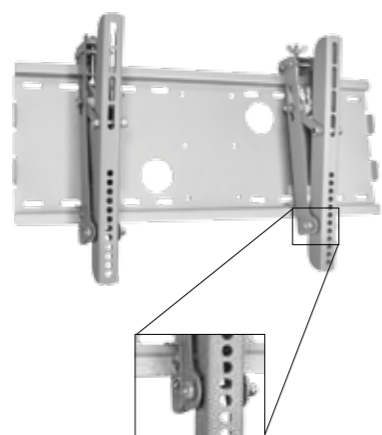

Tiltable TV Wall Mounts

**PB-14**

- Vertical tilt bracket  $\pm 15^\circ$
- Supports 37" - 63" screens
- Maximum loading capacity: 75kg
- Available in silver or black
- 800mm wide x (75 to 480mm) high

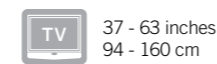

Available in Silver or Black

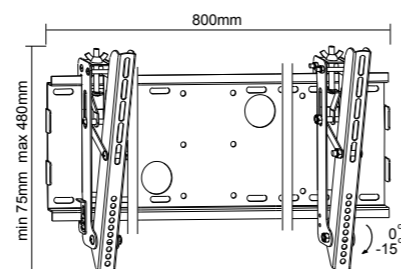
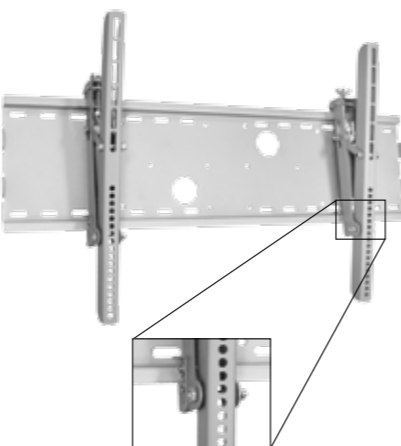

Articulated TV Mounts

**LDC-401AB**

- Swivel LCD Bracket (one pivot point)
- Supports VESA 50/75/100/200x100/200
- Supports up to 32" LCD Screens
- Maximum loading capacity: 30kg
- 90mm profile full extension
- 90° horizontal swing
- $\pm 20^\circ$  vertical tilt



Available in Silver or Black

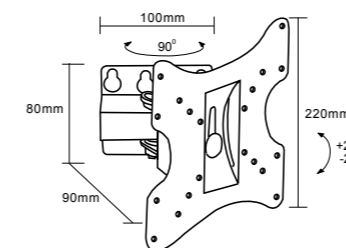

Articulated TV Mounts

**LDC-402AB**

- Swivel LCD Bracket (two pivot point)
- Supports VESA 50/75/100/200x100/200
- Supports up to 32" LCD Screens
- Maximum loading capacity: 30kg
- 330mm profile full extension
- 180° horizontal swivel (base) & 190° swivel (wrist)
- $\pm 20^\circ$  vertical tilt



Available in Silver or Black

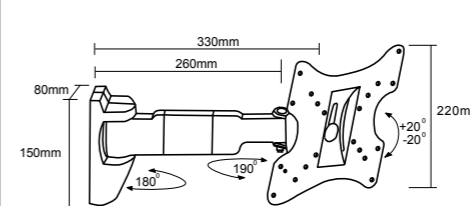
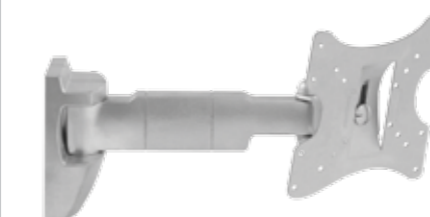

Articulated TV Mounts

**LDC-403AB**

- Swivel LCD Bracket (three pivot point)
- Supports VESA 50/75/100/200x100/200
- Supports 10" - 32" LCD Screens
- Maximum loading capacity: 30kg
- 450mm profile full extension
- 180° swivel (base & mid arm) & 190° swivel (wrist)
- $\pm 20^\circ$  vertical tilt



Available in Silver or Black

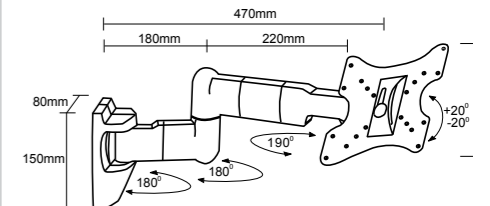

Articulated TV Mounts

Articulated TV Mounts

Articulated TV Mounts

Motorised TV Mounts

Motorised TV Mounts

**LDC-WA5B**

- Swivel LCD Bracket (three pivot point)
- Supports VESA 50/75/100/200x100/200
- Supports up to 32" LCD Screens
- Maximum loading capacity: 45kg
- 360mm profile full extension
- Double articulated arm
- $\pm 20^\circ$  vertical tilt

TV 10 - 32 inches  
25 - 81 cm

KG 45kg max.

VESA 50/75/100/  
200x100/200

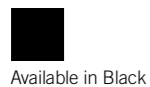

Available in Black

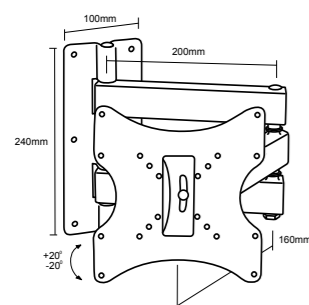

**PB-WA3A**

- Heavy Duty Plasma / LCD / LED Swivel Mount Bracket
- Allowances for 450mm / 600mm Stud Wall Spacing
- Supplied With PB-13, PB-14, PB-17 or PB-18
- Maximum loading capacity: 80kg
- Available in silver or black
- Maximum extension (355+290) mm long
- Ideal space saver! Folds flat against wall (85mm profile with PB-13 & PB17)

TV 37 - 63 inch (PB-13 or PB-14)  
94 - 160 cm

TV 23 - 32 inch (PB-17 or PB-18)  
58 - 81 cm

KG 80kg max.



Available in Silver or Black

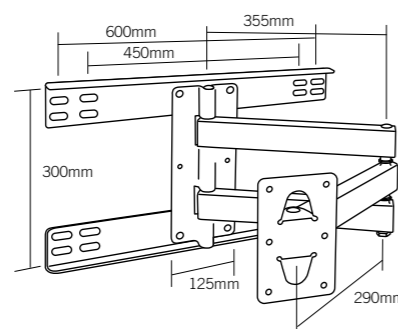
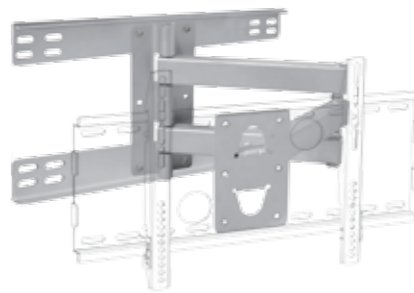

**PB-WA6**

- Super Heavy Duty Plasma / LCD Swivel Mount Bracket
- Allowances for 450mm / 600mm Stud Wall Spacing
- Swivel left & right up to 90° ( $\pm 45^\circ$ ) with  $\pm 15^\circ$  vertical tilt
- Maximum loading capacity: 80kg
- Ideal space saver! Folds flat to the wall (130mm profile)
- Sturdy Wishbone Design
- Maximum extension 300mm long

TV 27 - 63 inches  
68 - 160 cm

KG 80kg max.



Available in Silver or Black

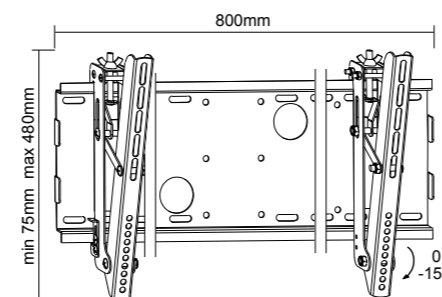

**LCD-M01**

- Motorised IR Remote Control Wall bracket
- Quiet built in motor
- Tilt: 15°, Swivel: 60°
- VESA 50/75/100/200

TV 23 - 37 inches  
58 - 94 cm

KG 30kg max.

VESA 50/75/100/200

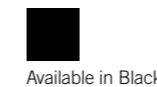

Available in Black

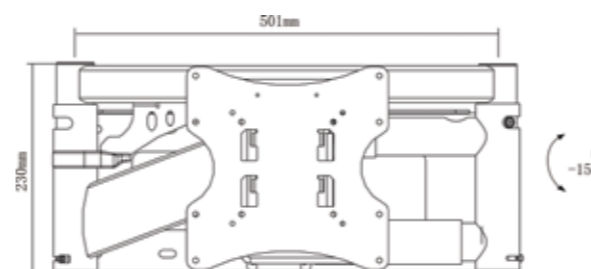

**LCD-M03**

- Motorised IR Remote Control Wall bracket
- Universal mounting pattern
- Max hole pattern 425mm x 450mm
- Smart space saving design (120mm profile)
- 4 intelligent motors
- 15° tilt, 45° swivel

TV 27 - 42 inches  
68 - 106 cm

KG 35kg max.

VESA 50/75/100/  
200x100/200



Available in Black

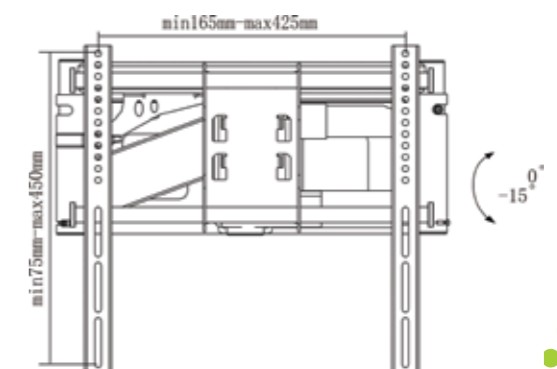

Low Profile Mounts

**PB-40B**

- Super Low Profile Design (19mm profile)
- Designed For Ultra Thin LCD/Plasma Screens
- Integrated Bubble Level
- Supports 23" - 37" Screens
- Maximum Loading Capacity: 75kg
- Locking bar for safety and security
- Max TV hold pattern (424mm wide 230 mm high)

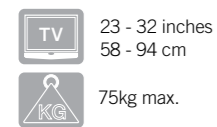

Available in Black

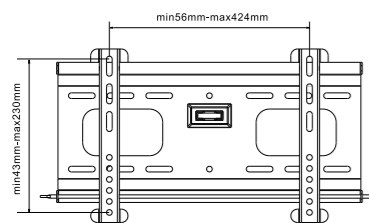

Low Profile Mounts

**PB-41B**

- Super Low Profile Design (19mm profile)
- Designed For Ultra Thin LCD/Plasma Screens
- Integrated Bubble leveller
- Safety Bar included for locking
- Supports 37" - 63" Screens
- Maximum loading capacity: 75kg
- 824mm wide x (75 to 410mm) high

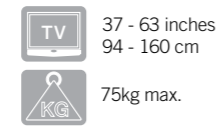

Available in Black

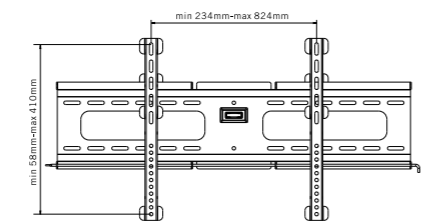

Low Profile Mounts

**LED-28**

- Ultra Low Profile Design (14.5mm profile)
- Designed For Ultra Thin LCD/Plasma Screens
- Integrated bubble leveller
- For 37" to 72" LED
- Easy mounting design
- Universal mounting patterns
- Maximum VESA 800\*800
- TV to wall: 14.5mm
- Easy connection for cables

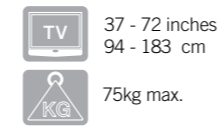

Available in Black

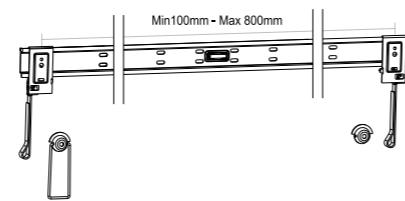

Projector Brackets

**PBR-1**

- Flush projector mount bracket - Universal
- Professional silver finish
- Maximum loading capacity: 10kg
- Supplied with two pipe lengths: 80mm & 150 mm
- No cutting into ceiling required
- 15° tilt and roll adjustment



Available in Silver

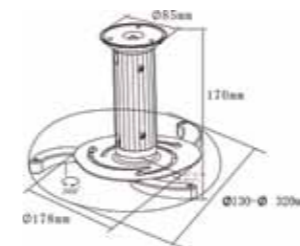

Projector Brackets

**PBR-4**

- Projector mount bracket - Universal
- Ceiling & wall mountable
- Professional silver finish
- Maximum loading capacity: 10kg
- Supplied with two pipe lengths: 150mm & 400mm
- No cutting into ceiling/wall required
- 30° tilt and roll adjustment



Available in Silver



Projector Brackets

**PBR-10**

- Ceiling Projector Bracket
- Tilt:-20°~+20°, Swivel:360°
- Universal Mounting Pattern
- Ceiling to Projector: 575mm~825mm
- With cable management
- Load Capacity: 20kgs
- Black colour



Available in Black



Ceiling Mounts

Ceiling Mounts

Ceiling Mounts

Ceiling Mounts

Desktop / Table Mounts

Desktop / Table Mounts

**PBL-CE3**

**Single**

- Heavy duty ceiling mount bracket
- Supplied with 1x PB-14 or 1x PB-18
- Maximum loading capacity: 80kg
- Full cable management (cables inside pole)
- Pole height adjustable from 1000 to 2000mm
- Full 360° horizontal pole spin

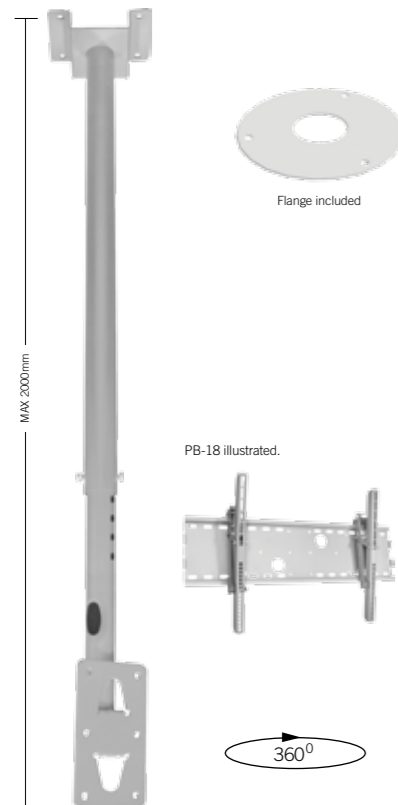
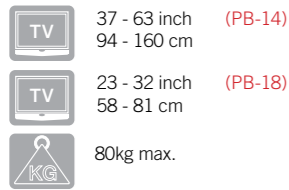

**PBL-CE3D**

**Double - Back to Back**

- Heavy duty ceiling mount bracket
- Supplied with 2 x PB-14 or 2 x PB-18
- Maximum loading capacity: 150 kg
- Full cable management (cables inside poles)
- Pole height adjustable from 1000 to 2000mm
- Full 360° horizontal spin

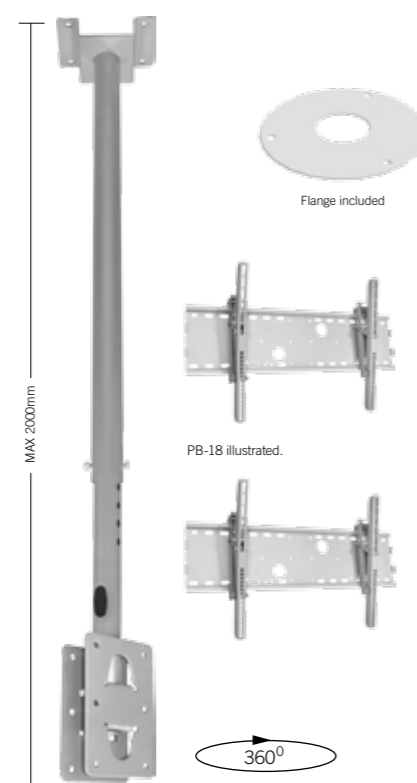
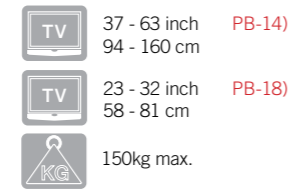

**LDC-CE5**

- LCD ceiling mount bracket
- Supports VESA 75/100/200x100/200
- Supports up to 32" screens
- Maximum loading capacity: 30 kg
- Full cable management (cables inside poles)
- Pole height adjustable from 1000 to 2000mm
- Full 360° horizontal spin with ±20° vertical tilt

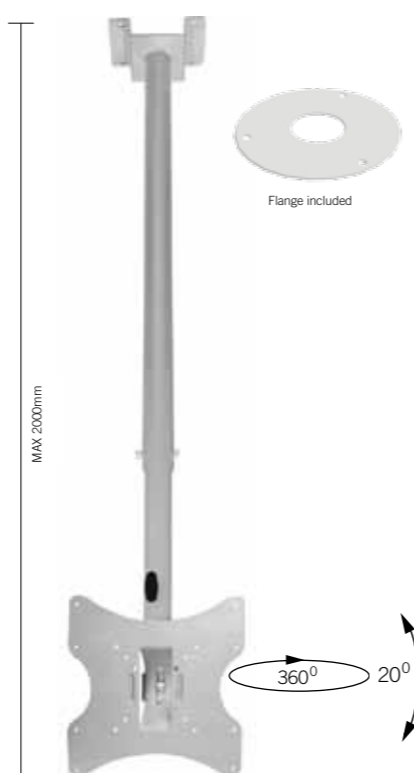
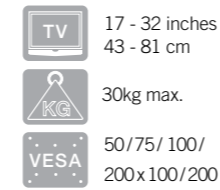

**LDC-504AB**

- LCD ceiling mount bracket
- Supports VESA 50/75/100/200x100/200
- Supports up to 32" screens
- Maximum load capacity: 30kg
- Full cable management (cables inside poles)
- Pole height adjustable from 500 to 850mm
- Full 190° horizontal spin with ±20° vertical tilt

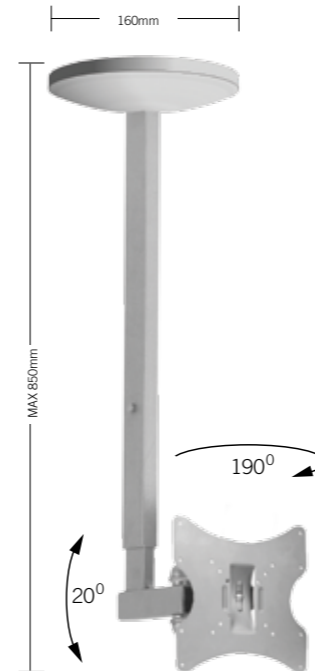
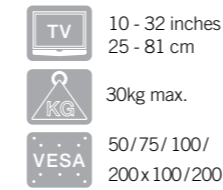

**LDC-T6**

- Table mount bracket
- Supports VESA 75 / 100
- Supports 17" - 24" Screens
- Maximum loading capacity: 15kg
- C-Clamp attachment
- Max height adjustment: 415mm tall
- Tilt ±60° Swivel 360°

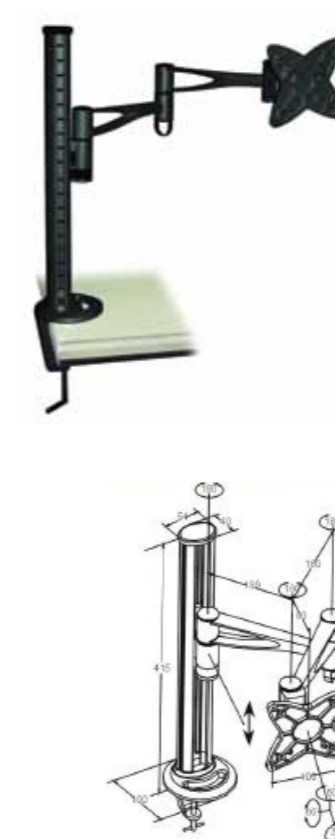
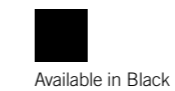
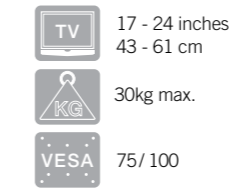

**LCD-T9**

- Table mount bracket
- Supports VESA 75 / 100
- Supports 17" - 24" Screens
- Maximum loading capacity: 15kg
- C-Clamp attachment
- Max height adjustment: 415mm tall
- Tilt ±30° Swivel 360°

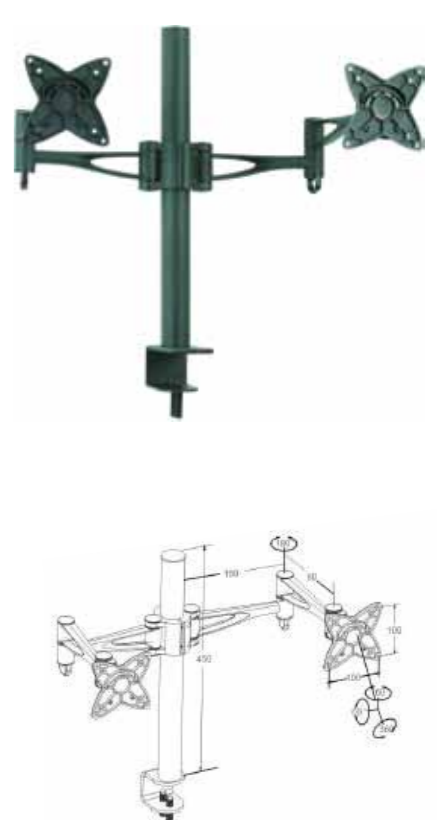
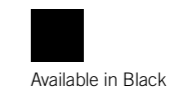
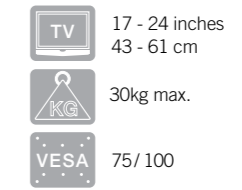

Tradeshow & Digital Signage

Tradeshow & Digital Signage

Tradeshow & Digital Signage

AV Furniture

AV Furniture

**QAVS-102**

- Fixed wall bracket
- Universal mounting pattern
- Max. Hole pattern 225mm wide and 770mm high
- Max. VESA: 200 x 600mm
- TV to wall: 32mm

 37 - 60 inches  
94 - 150 cm

 50kg max.



**QAB-K112**

- Tradeshow Display Stand with integrated Plasma / LCD / LED mount bracket
- Height: 1750mm
- 2 x black tempered 6.0mm glass shelves
- Base: 900 x 500mm
- Maximum weight: 50kg
- Full Cable Management

 37 - 55 inches  
94 - 140 cm

 50kg max.



**QAVS-102**

- Mobile Display Stand with integrated Plasma / LCD / LED mount bracket
- Height: 1350mm
- Adjustable black metal shelf
- Heavy-duty lockable caster wheels
- Maximum weight: 50kg

 37 - 55 inches  
94 - 140 cm

 50kg max.



**QFAVS-19B**

- AV furniture stand with integrated Plasma / LCD / LED mount bracket
- One simple complete solution
- Black tempered 8.00mm glass shelves with black aluminium alloy column
- Swivel 90° (45° either side of centre)
- Maximum weight: 50kg
- Base: 1100 x 550mm
- Height: 1160mm

 37 - 55 inches  
94 - 140 cm

 50kg max.



**QN1000**

- AV furniture stand with integrated Plasma / LCD / LED mount bracket
- One simple complete solution
- Black tempered glass shelves with black ash wooden column
- Anti scratch surface
- Maximum weight: 50kg
- Base: 1300 x 400mm
- Height: 1350mm

 37 - 55 inches  
94 - 140 cm

 50kg max.





AV Furniture

**QLK-1**

- AV furniture stand with integrated Plasma / LCD / LED mount bracket
- One simple complete solution
- Black tempered 8.0mm glass shelves with black MDF drawers, silver aluminium column
- Swivel 90° (45° either side of centre)
- Maximum weight: 50kg
- Base: 1300 x 440mm
- Height: 1300mm

 37 - 55 inches  
94 - 140 cm

 50kg max.



AV Furniture

**QL102**

- AV furniture stand with integrated Plasma / LCD / LED mount bracket
- One simple complete solution
- 2 x black tempered 8.0mm glass shelves with black MDF drawers, silver aluminium column
- Swivel integrated bracket with ±15° tilt
- Maximum weight: 50kg
- Base: 1200 x 440mm
- Height: 1250mm
- Hidden Wheels

 37 - 55 inches  
94 - 140 cm

 50kg max.

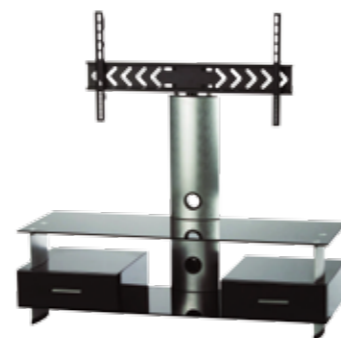

AV Furniture

**MTS-006**

- Motorized Left & Right swivel:30°
- Motorized Stand height adjustment: 1130~1550mm
- Glass dimension: 1000x500mm
- Includes AC/DC adaptor and remote control
- Load Capacity: 50kgs

 37 - 55 inches  
94 - 140 cm

 50kg max.



AV Furniture

**DVD-7B**

- 2 Shelf DVD Bracket
- 6mm Black Tempered glass shelf
- 430mm depth 500mm width
- Adjustable 500mm height extension
- Available in Black Only
- Full cable management

 10kg max.

 Available in Black

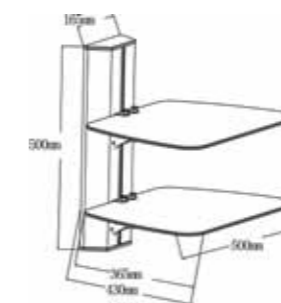

CABLES AND ACCESSORIES

**QM-8040 Series**

**QM-8040.010**

- Supports 1080p
- HDMI 1.4 Compliant - 3D TV
- Braided Premium Cables
- Gold Plated Zinc Alloys Connectors
- 10 metre cable length



**QM-8040.030**

- Supports 1080p
- HDMI 1.4 Compliant - 3D TV
- Braided Premium Cables
- Gold Plated Zinc Alloys Connectors
- 3 metre cable length



**QM-8040.100**

- Supports 1080p
- HDMI 1.4 Compliant - 3D TV
- Braided Premium Cables
- Gold Plated Zinc Alloys Connectors
- 1 metre cable length



### Projection Screens

#### PDSC-100

- Tripod projection screen - 100" diagonal
- 100" Diagonal, (2.0m wide x 1.50m high)
- 4:3 aspect ratio
- Matte white screen surface
- Double scissor locking mechanism - stable base
- Keystone eliminator

This masterfully crafted, high quality 'matte white' tripod screen has a viewable area of 2.0m wide x 1.50m high and is in a native 4:3 aspect ratio when fully extended, perfect for your mobile computer presentations and home theatre applications. Any projection technology such as LCD, DLP and CRT are all compatible with this screen and viewing pleasure will be enhanced dramatically.

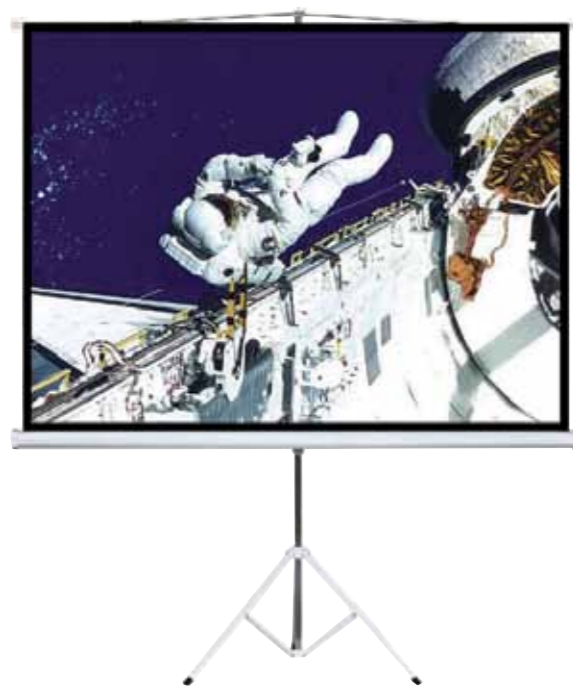

### Projection Screens

#### PSAC-100 PSAC-150 PSAC-300 PSAA-90

- a) Electronic 100" (2.0m x 1.5m), 4:3 aspect ratio (PSAC-100)
- b) Electronic 150" (3.0m x 2.2m), 4:3 aspect ratio (PSAC-150)
- c) Electronic 300" (6.0m x 4.4m), 4:3 aspect ratio (PSAA-300)
- d) Electronic 90" (2.0m x 1.12m), 16:9 aspect ratio (PSAA-90)

- Stylish RF Remote control included with hand control switch
- Matte white screen surface
- White casing
- Incorporated brackets on case for ceiling or wall mount
- Motor type: Tubular motor
- With up/down/stop switch

This masterfully crafted, high quality, 'matte white' electric screen comes in four different sizes and is in a native 4:3 aspect ratio, perfect for your computer presentations and home theatre applications. Any projection technology such as LCD, DLP and CRT are all compatible with this screen and viewing pleasure will be enhanced dramatically.



### Projection Screens

#### PSBC-100 PSBA-90

- Manual - 100" (2.0m x 1.5m), 4:3 aspect ratio (PSBC-100)
- Manual - 90" (2.0m x 1.12m), 16:9 aspect ratio (PSBA-90)

- Matte white screen surface
- White casing
- Screen auto lock system on pull down
- Incorporated brackets on case for ceiling or wall mount

This masterfully crafted, high quality 'matte white' screen has two different viewable area sizes and is in a native 4:3 aspect ratio, perfect for your computer presentations and home theatre applications. Any projection technology such as LCD, DLP and CRT are all compatible with this screen and viewing pleasure will be enhanced dramatically.



### Projection Screens

#### PSAG-108

- Fixed projection screen - 108" diagonal
- 108" Diagonal, (2.4m wide x 1.35m high)
- 16:9 aspect ratio
- Matte white screen surface
- Quality aluminium fixed frame

This masterfully crafted, high quality 'matte white' screen has a viewable area of 2.4m wide x 1.35m high and is in a native 16:9 aspect ratio, perfect for your home theatre applications. Any projection technology such as LCD, DLP and CRT are all compatible with this screen and viewing pleasure will be enhanced dramatically.





## Quantum Sphere Proudly manufacturing and marketing Q-Tee Brackets and Mounts

Quantum Sphere is the leading wholesaler of a wide range of top-brand, commercial-quality audio visual appliances, display mounts & brackets and more.

We're here to handle the equipment supply and delivery requirements of commercial installers, major corporations, and specialist audio visual retailers.

As an Australia-wide operation, we have the logistical capacity and the warehousing capabilities to service urban, regional, and remote areas throughout the country. And we regularly do, for installers all around the country and for large corporate clients such as the Commonwealth roll-out of customer interface equipment for the bank's ongoing branch refit project.

We are an authorised dealer for LG, Sony, Panasonic, NEC and Samsung, so we can provide you with a comprehensive range of Plasma, LCD and LED screens, TVs, DVD/CD units, Blue Ray gear, Projectors, Screens, Home Theatre Equipment, Entertainment boxes, Whitegoods, and more.

Our team specialise in providing customised installation services and work in partnership with individuals, consultants, and organisations to provide dependable, high-performance solutions that are not only designed to withstand high-usage with reliability, but are cost effective too.

With Quantum Sphere, you have access to a commercial wholesaler possessing a terrific track record, the latest technical know-how,

convenient multi-location warehousing, and a reliable supply and fulfillment chain. That's great for your business reputation as well as being good for your customers.

The upshot is that your clients, your staff, or your end-users will be able to fully interact with the latest sophisticated audio visual and home & office technology tools, with ease and confidence...

all at low wholesale prices. That's why we're the gateway to excellence.

### Our Core Values

Integrity, Quality, Professionalism, Efficiency and Competitiveness



### Why buy from an Authorised Dealer?

Quantum Sphere is not only an authorised dealer for some of the world's best brands in information and entertainment delivery, we're also one of the category's leading commercial wholesalers. As a result, we're able to pass on access to product ranges and pricepoint alternatives that other non accredited, non-authorised operators are simply not able to.

Our win/win relationships with respected brands ensure that our clients get looked after. With the right technical advice, back-up and support when you need it, warehousing and fulfillment with no

unpleasant surprises, and above all, access to great long-lasting products at very competitive prices.

Many 'no-name' brands are here today and gone tomorrow. And unfortunately, most of the 'made up' brand names we've come across simply don't deliver, day-in, day-out performance with an acceptable level of ongoing reliability. Many don't provide a dependable parts and servicing channel either.

You get what you pay for, and it's simply false economy to buy cheapest when you factor in recall rates, end-user dissatisfaction, and the potential litigation risk due to non-performance or damage risk. We won't risk our reputation, or yours, by stocking them.

Quantum Sphere bypass the 'fly by nighters' and stick only with the big brands. So you can be assured that we really can deliver on the values we hold dear to our organisation... integrity, quality, professionalism, efficiency, and competitiveness.

### You can trust Quantum Sphere.

The best way to judge a long-term supplier is to talk to its customers. Those that have used us will tell you: 'Quantum Sphere is a company worth doing business with'. We look forward to being of service to you.

[www.qsphere.com.au](http://www.qsphere.com.au)

Q-Tee is a registered trademark of Quantum Sphere Pty Ltd.

PO Box 6077, Dural, NSW 2158, Australia

Phone 1300 571 188

Fax 61 2 8569 0655

Email [sales@qsphere.com.au](mailto:sales@qsphere.com.au)

[www.q-tee.com.au](http://www.q-tee.com.au)

