



XL ELECTRIC LIFT MOBILE STAND

FPS1XL/EL/GG



Take control of creative, presentation and collaboration work spaces. Salamander's beautiful and highly functional FPS Series Mobile Stands offer superior ergonomics complimenting any touch screen display with improved productivity, unrivaled flexibility and lifetime value.

A stylish, sleek and compact design moves easily between spaces. A thoughtful range of accessories provides even more utility and an improved user experience.

- Mobile stand for interactive display / touchscreen panel
- Motorized Electric Lift and wired remote control
- Compatible with most large displays including 98" Screens, see VESA pattern and weight limits.
- Ergonomic design. Adjustable height positioning provides best possible ergonomics and viewing.
- Superior mobility. High quality, commercial grade locking casters and integrated handles provide easy maneuverability and transport
- Fully concealed cable management allows clean and uncluttered installation
- Range of travel, Center of screen: Min - 38.16" (969 mm) and Max 63.75" (1619 mm)
- Storage for electronic components, peripherals and accessories.
- Telescopic design allows compact position for transport and storage
- Durable construction. Made in USA of powder coated steel, Linak Motor components, Powder coated and/or veneered MDF panels
- Options available for peripheral equipment mounting, retractable cable reel, secure equipment storage cover, keyboard tray and more.
- Limited Lifetime Warranty





XL ELECTRIC LIFT MOBILE STAND

FPS1XL/EL/GG

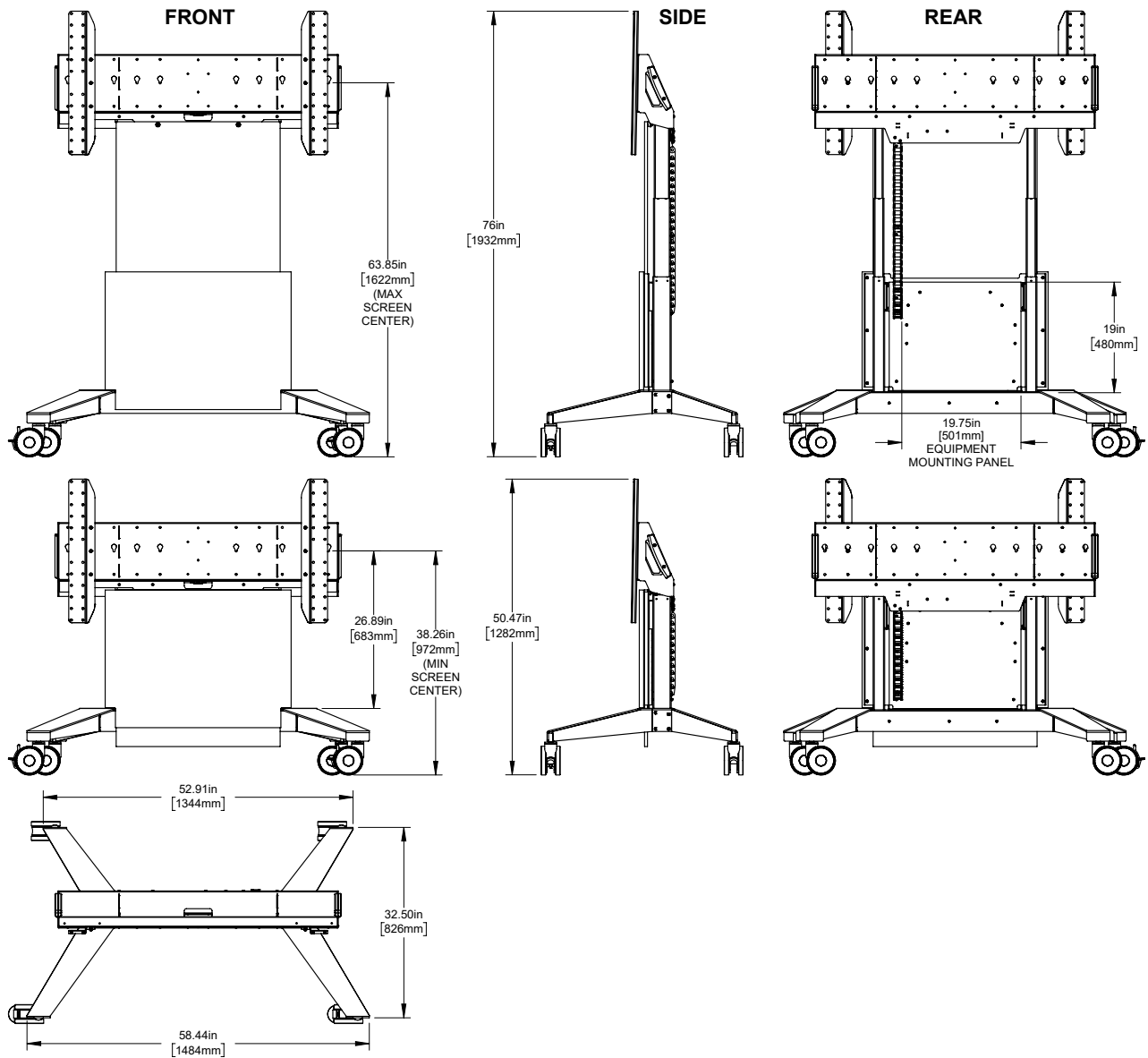



XL ELECTRIC LIFT MOBILE STAND

FPS1XL/EL/GG

PRODUCT SPECIFICATIONS	Metric (mm)		US/Imperial Inches		SHIPPING DIMENSIONS	
	Length	1484.3	58.44	1,251 mm	49.25 inch	
Overall Height Range	1280.3 - 1930.3	50.41 - 76	1,048 mm	41.25 inch		
Center of Screen Range of Travel	969.2 - 1619.2	38.12 - 63.75				
Depth	825.5	32.5	368 mm	14.5 inch		
Weight	74.84 kg	165 lbs	86 kg	190 lb		
Max Load Capacity	136 kg	300 lbs				
UPC Number	634878507141					

VESA COMPLIANT MOUNT PATTERN

Horizontal - 400, 500, 600, 700, 800, 900, 1000, 1100, 1200, 1300mm
 Vertical - 100, 200, 300, 400, 500, 600mm
 Panel Mounting - M8 Machine Screws

Includes Microsoft Surface Hub 2 Mounting adapter (CA/MAC4) VESA 350mm x 350mm

CASTER WHEELS

5" (125mm) HD, Non Marking, Brakes on 2

ELECTRICAL INFORMATION

Input: 90V - 240V ~, 48 Hz - 63HZ
 Duty Cycle: 10% Max 2min / 18min

CABLE MANAGER CHAIN

1" x .75" x 34" (25 x 19 x 865mm)

POWER CABLE

IEC - Type Class 2, 2-prong
 USA Included: (PN 400-590)

Available:
 EU (PN 400-591)
 UK (PN 400-592)
 New Zealand, Australia and others (PN 400-593)



FPS1XL/EL/GG
 E479586





XL ELECTRIC LIFT MOBILE STAND

FPS1XL/EL/GG

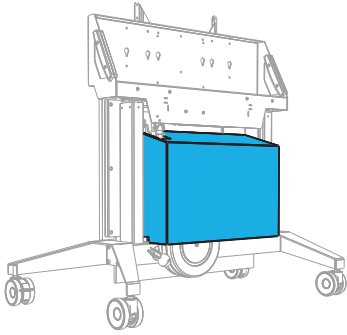

Equipment Storage Cover- Graphite
FPSA/SC/GT

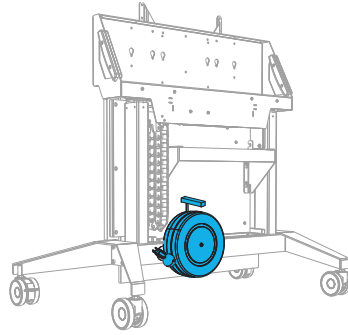

Cable Reel 30' Payout, 24" Tri-Tap Female End
FPSA/CR

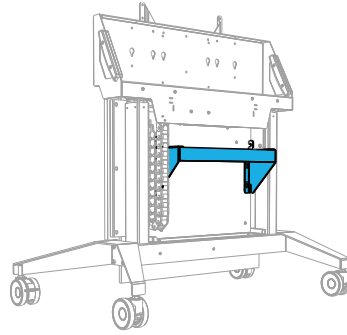

19" Rack Mounting 3 RU
RM/VR/3U

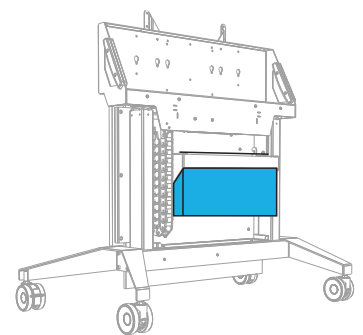

Power Distribution Unit
SA/RM/PDU

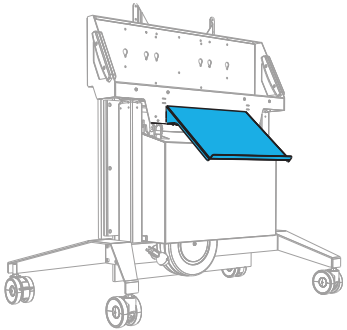

Keyboard Storage Shelf- Graphite
FPSA/KS/GT

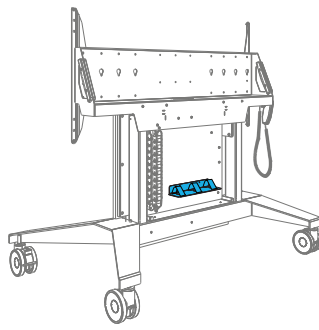

Accessory Shelf with Straps
FPSA/AS1

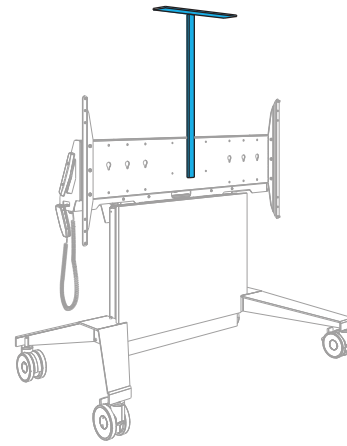

Camera Mount Shelf
FPSA/CS

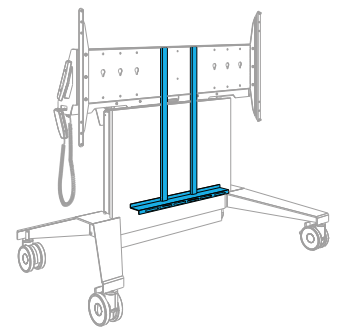

Speaker Bracket Kit
FPSA/SBK

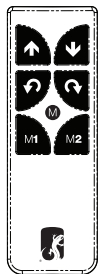

Wireless RF Remote Control with Memory
FPSA/RF1

ROAD CASE

FOR EASY DEPLOYMENT

Combine a mobile stand with a road case to provide secure and convenient transport of your display.

Accommodates Stand & Display

FPSA/RC/XL

